

Extruded Aluminum Louver • 6" Deep • 35° Drainable Blades • Airfoil Adjustable Blades • Concealed Mullion

Standard Construction and Materials

- FRAME:** .081" thk. (nominal) extruded aluminum, 6063-T52/T6 alloy. Channel type frame.
- BLADES:** Stationary blades made from .081" thk. (nominal) extruded aluminum 6063-T52/T6 alloy. Adjustable Airfoil blades made from .125" thk. (nominal) extruded aluminum 6063-T52/T6 alloy. Blades are approximately 4½" on centers.
- LOUVER FACE:** Full width sill with head and blades contained within jambs. Concealed mullion with continuous length stationary blade.
- LINKAGE:** Extruded aluminum, concealed in the channel out of the airstream. The pivots, which rotate in Celcon bearings, are .50" dia. Zinc plated machined steel. The pivot is locked to the 5/16" dia. aluminum linkage rod by a ¼ - 20 set screw with an epoxy locking patch.
- BEARINGS:** Celcon bearing material, so there will be no metal to metal friction.
- SHAFTS:** .50" dia. aluminum "Pin-Lock" rod.
- SEALS:** Extruded silicone rubber seals at blade edge. Foam on bottom blade and polycarbonate jamb seals. Stainless steel at jamb required on painted louvers.
- SCREEN:** (When indicated, in a removable frame)
 - ½" flattened aluminum, .051" thk.,
 - or- Insect screen 18/16 aluminum mesh, .011" dia.,
 - or- ½" sq. mesh intermediate double crimped aluminum wire, .063" dia.
- FINISH:** Mill.

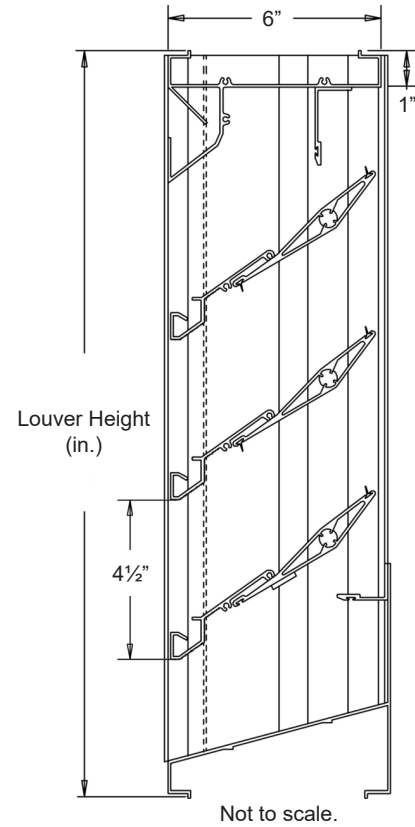

Options

- Finishes - Enamels, Epoxies, etc.
- Other screens also available.
- Actuators - Electric, Pneumatic, Manual, etc.

Notes

1. Nominal deductions will be made to the opening size given.
2. Approximate shipping weight is 5.7 lbs./sq.ft.

Louver Sizes

Min Panel	Max Single Panel
12"W x 19"H	96"W x 72"H

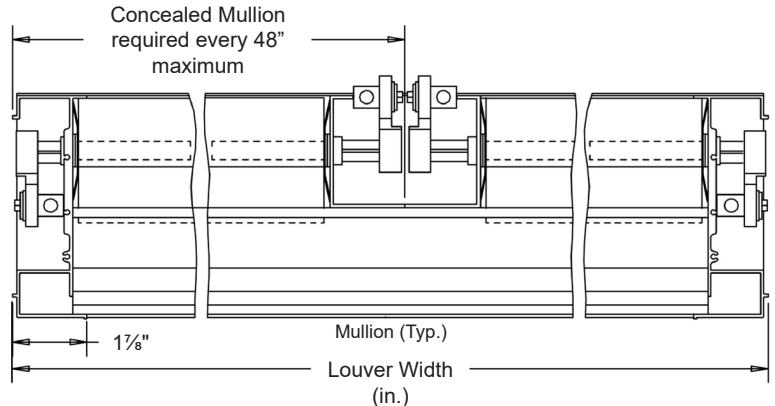
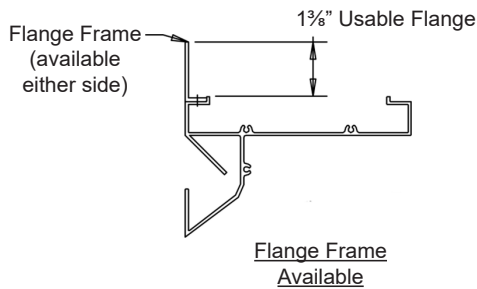

Item #	Qty	Width	Height	Width	Height	Mullion	Type	Location		
		Opening Size		Louver Size			Screens		Union Made	
Arch. / Eng.:						EDR:		ECN:	Job:	
Contractor:										
Project:						Date:	DWN:	DWG:		

In the interest of product development, CESCO Products reserves the right to make changes without notice.



450 Riverside Dr • Wyalusing PA, 18853
 Phone: 570-746-1888 • Fax: 570-746-9286
 www.cescoproducts.com